

Bottom Rails

Part 1003- Morgan Bottom Rail GVFD & GVSD

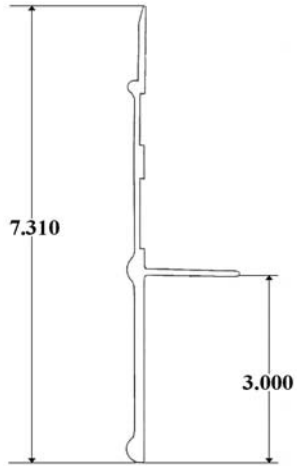

Part 1005- Morgan Bottom Rail GVFD
New Style

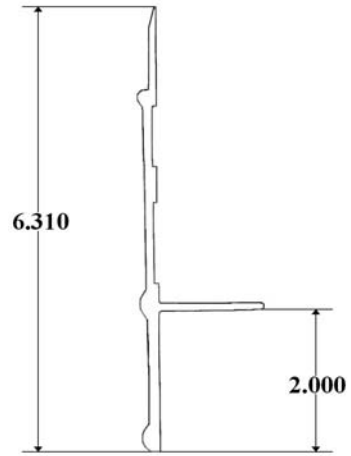

Part 1008F- Morgan Bottom Rail GVFD
From 97 to Present

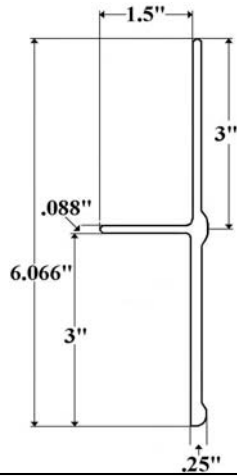

Part 2003- Supreme Bottom Rail

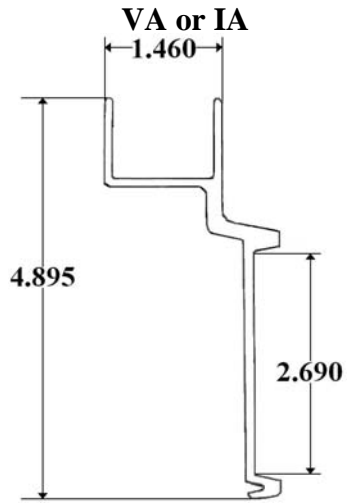

Part 2003F- Supreme Bottom Rail

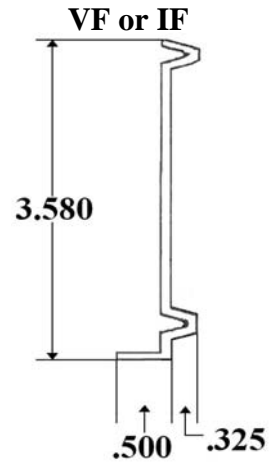

Also Replacement for Duralite

Part 2004F- Supreme Bottom Rail

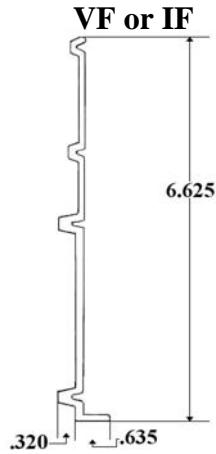

Also Replacement for Modern Wagon

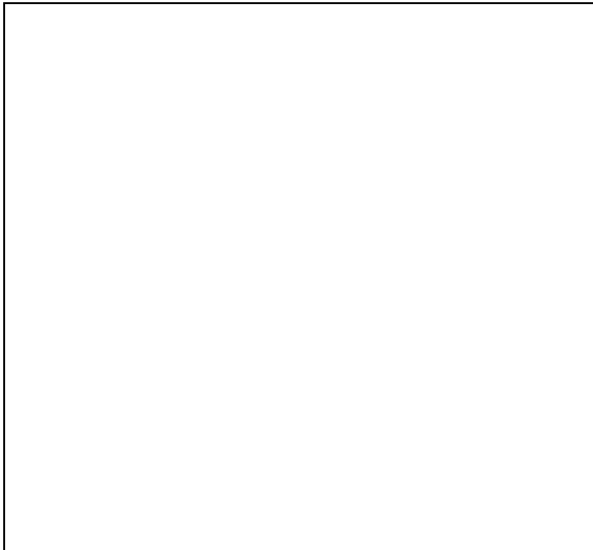

Part 3003- Utilimaster Bottom Rail

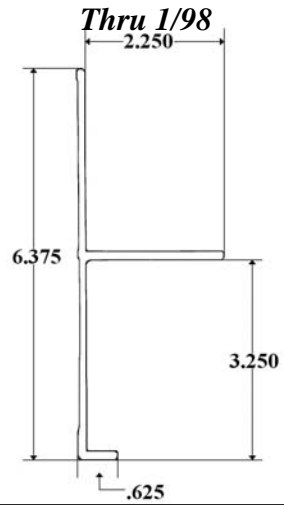

Part 3004- Utilimaster Bottom Rail

From 2/98

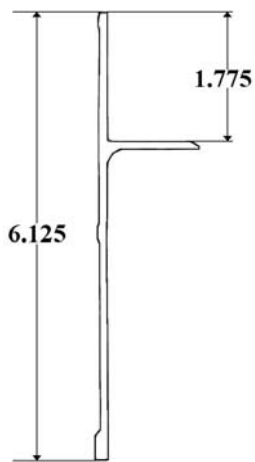

Part 3005- Utilimaster Bottom Rail

New Style

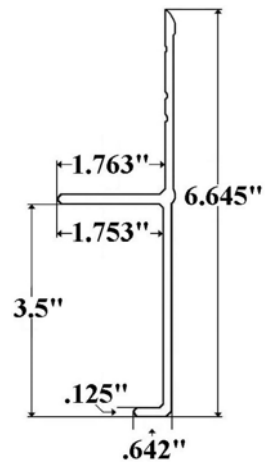

Part 305-2- Bottom Rail U.S. Truck



See Casting #322-5

Part 307-2- Bottom Rail U.S. Truck

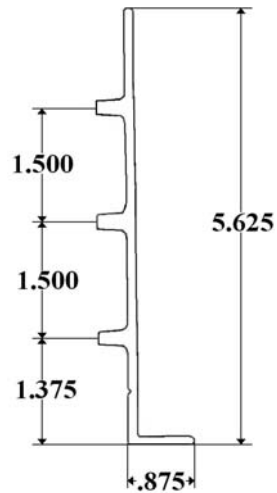

Part 4003- Bottom Rail Grumman

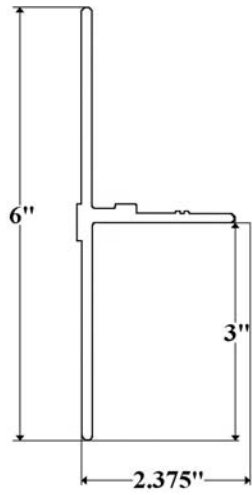

Part 5003- Bottom Rail Kidron

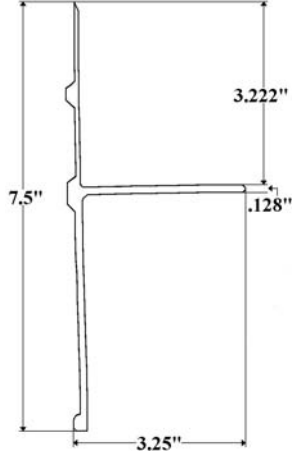

Will Replace Delta FZ, Gindy & Vanco

Part 6003- Bottom Rail Mickey

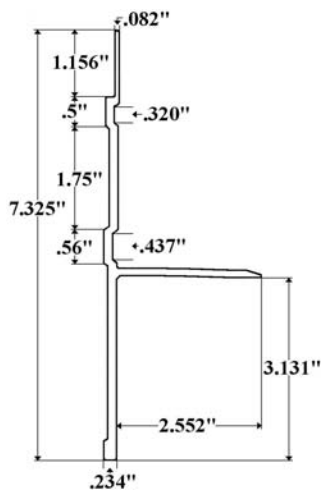

Part 7003- A. M. Haire Bottom Rail

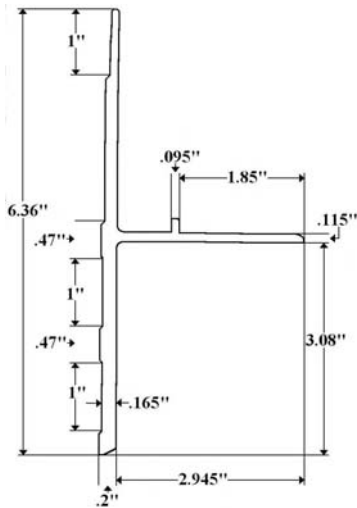

Part 7703- ABC Body Bottom Rail

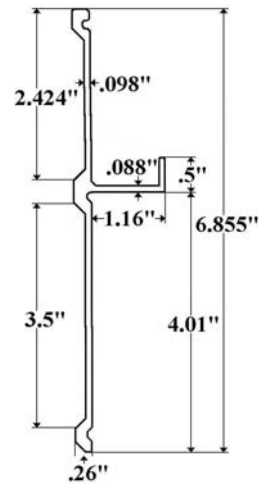

Part 8003- Bottom Rail A/C

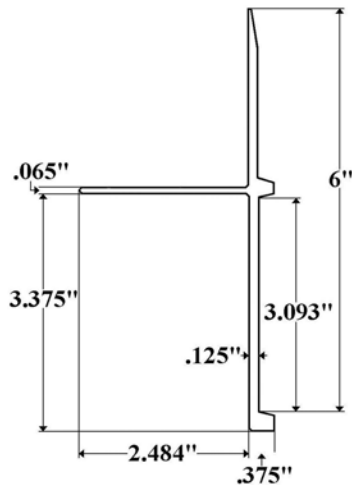

Part 9003- Babb Bottom Rail New Style

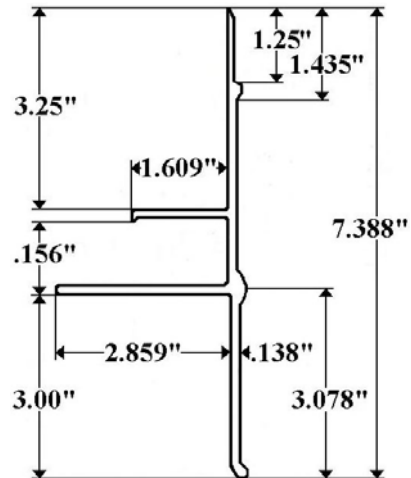

Part 9903F- Marathon/Satellite/Metro Bottom Rail

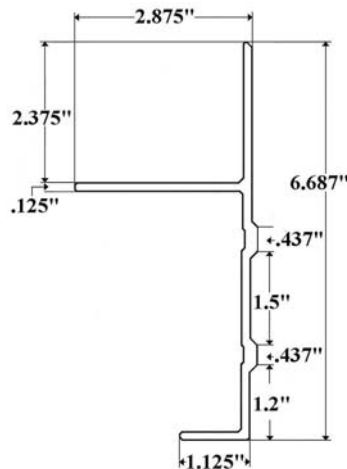

Part TRVBOT- Bottom Rail Babb, Trail-R-Van, Delta QX

