

# Top Rails

**Part 00117- Duralite Top Rail**

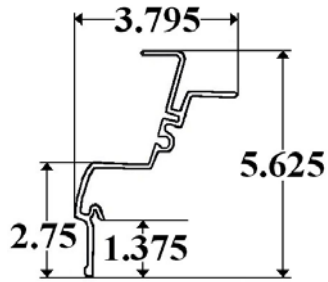

**Part 1002- Morgan Top Rail 1-3/8" Roof  
Bow GVSD Thru 3/97**

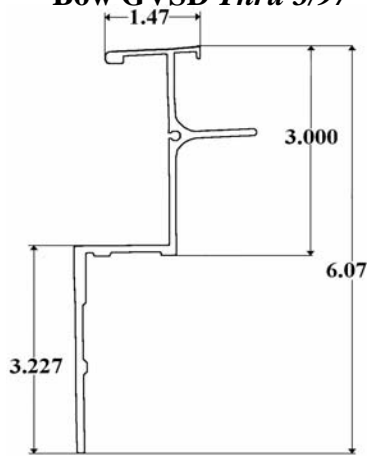

**Part 1002F- Morgan Top Rail 1-3/8" Roof  
Bow GVFD Thru 3/97**

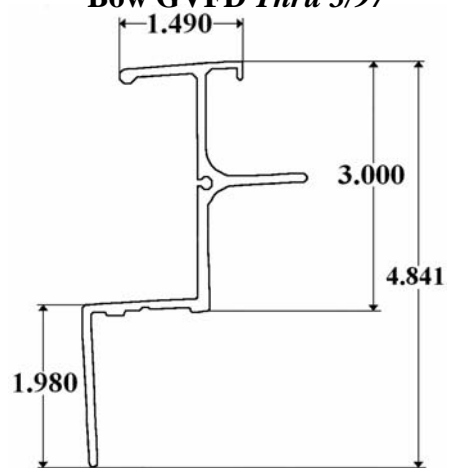

**Part 1006- Morgan Top Rail GVSD**  
*New Style 1" Roof Bow*

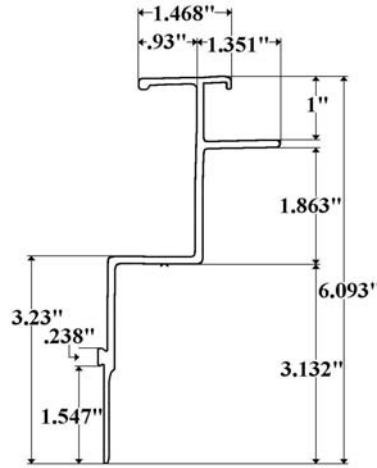

**Part 1006F- Morgan Top Rail GVFD**  
*New Style 1" Roof Bow*

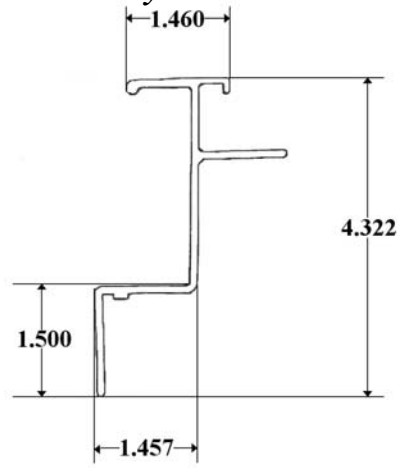

**Part 1007F- Morgan Top Rail GVFD**  
*1" Roof Bow New for 2003*

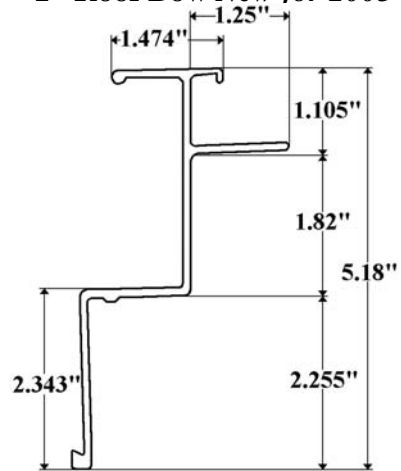

**Part 1009- Morgan Top Rail GVSD**  
*1" Roof Bow From 4/97*

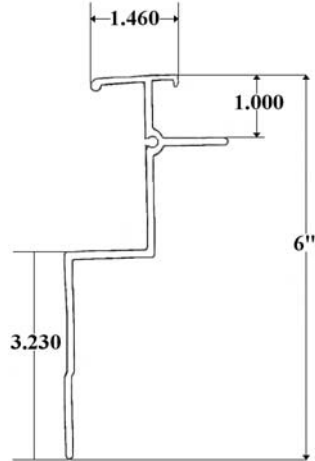

**Part 1009F- Morgan Top Rail GVFD**  
*1" Roof Bow From 4/97*

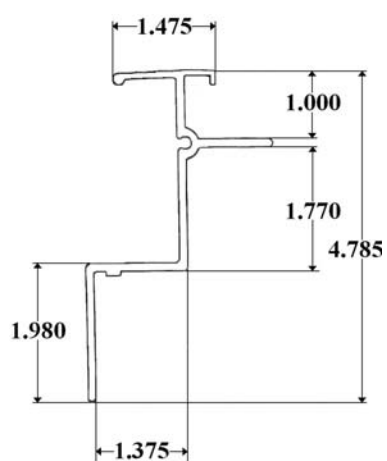

**Part 2002- Supreme Upper Top Rail  
VA or IA**

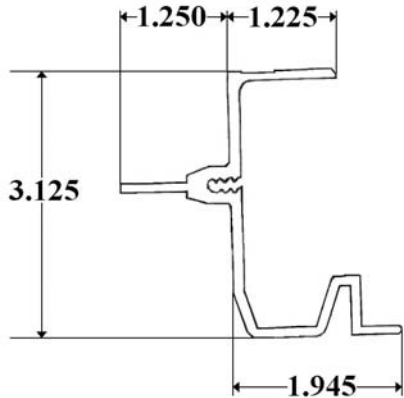

**Lower Use Universal Rail (UR)**

**Part UR- Universal Rail Supreme-  
Lower of 2 PC Top Rail  
for Aluminum Body**

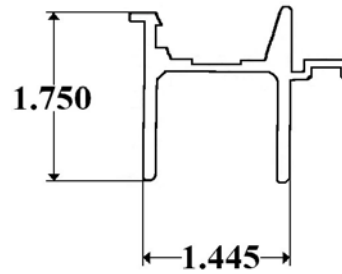

**Rear Connector Aluminum Body,  
Side Door Frame Aluminum Body**

**Part 2002F- Supreme Top Rail  
VF or IF**

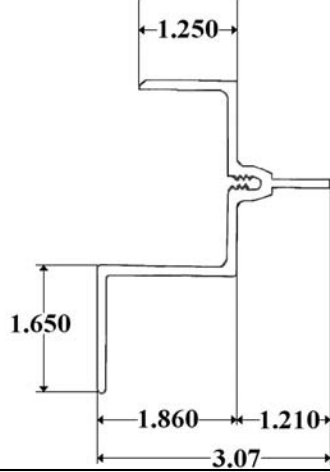

**Part 2009F- Supreme Top Rail  
VF or IF**

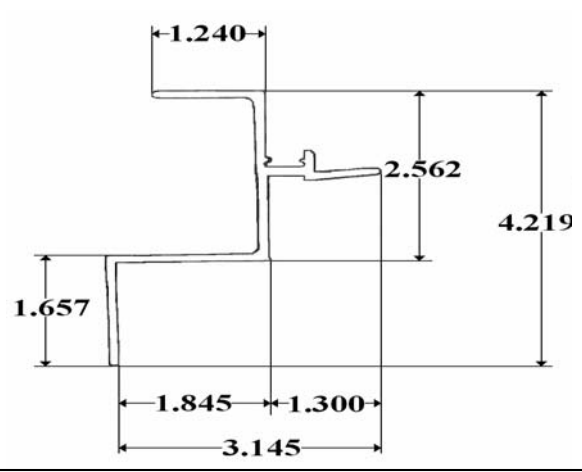

**Part 2117- Top Rail**

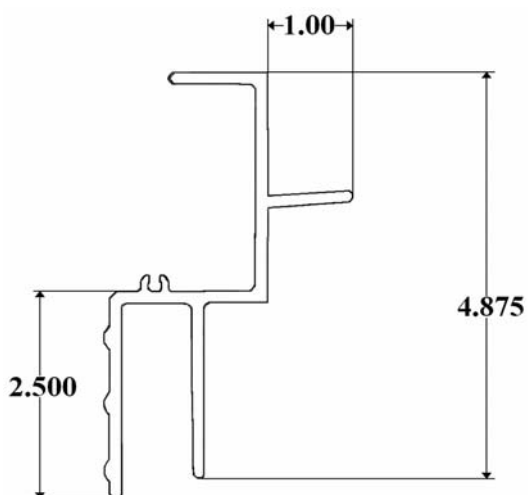

**Part 2121-Top Rail**

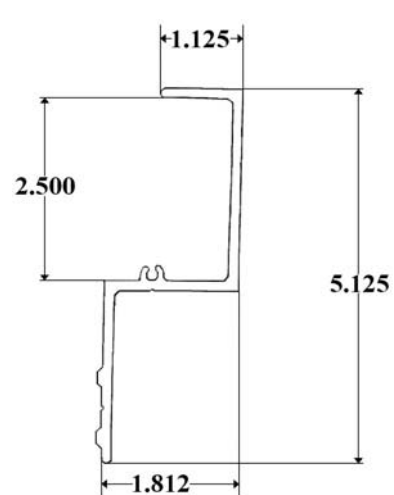

**Part 3002- Utilimaster Top Rail**

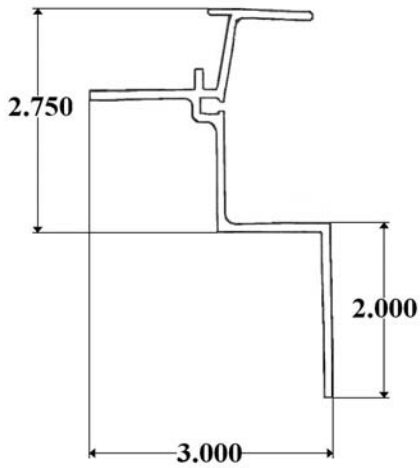

**Part 3007- Utilimaster Top Rail New Style**

**Part 3009- Utilimaster Rear Top Rail**

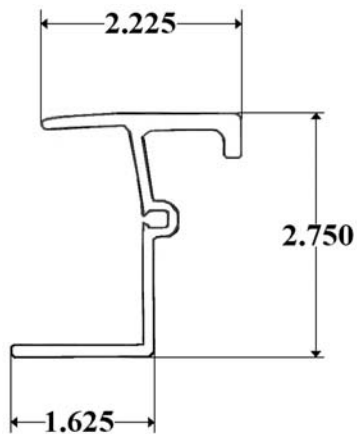

**Part 366-2- Top Rail Lower U.S. Truck Aluminum Body**

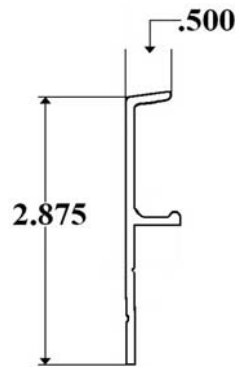

**Upper 422-2**

**Part 367-2 - U.S. Truck Body New Style Top Rail (Lower Piece on Alum. Body)**

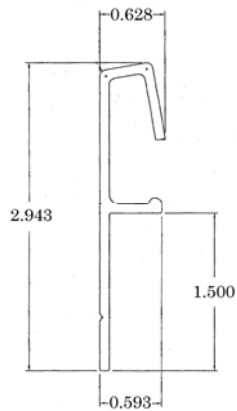

**Part 3902- Modern Wagon Top Rail**

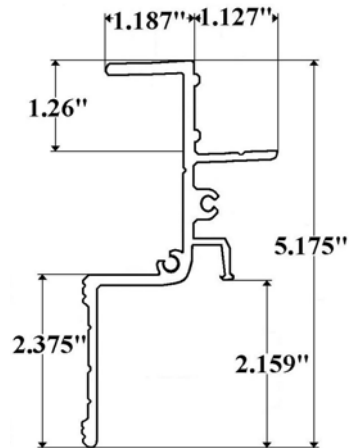

**Part 403-2AG- U.S. Truck Top Rail Rear**

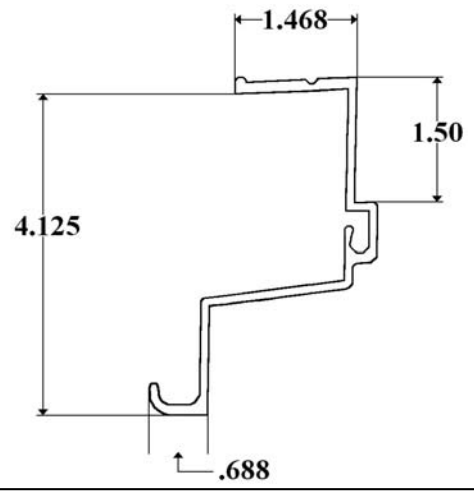

**Part 422-2- Roof Cove U.S. Truck**

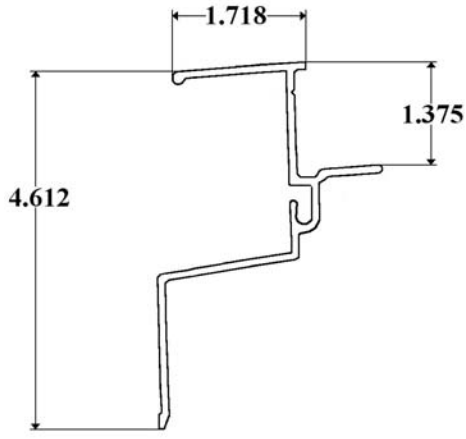

**Used with 366-2 Aluminum Body Only**

**Part 423-2 - U.S. Truck Body New Style Roof Cove (Upper Piece on Aluminum & FRP Body)**

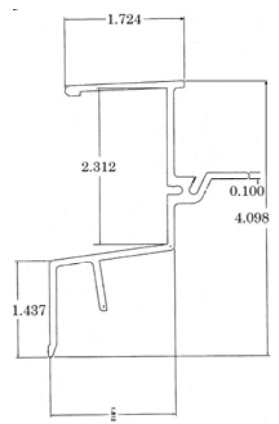

**Part 4002- Top Rail Grumman**

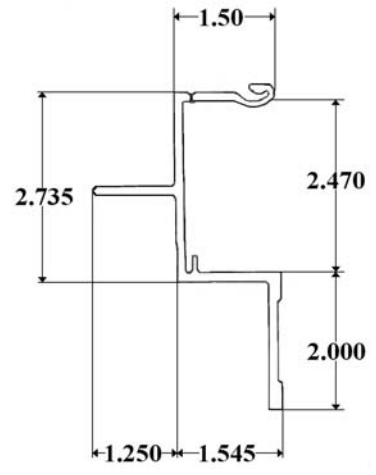

**Interlock for Grumman Top Rail**

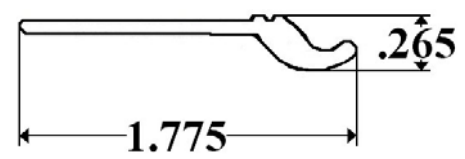

**Use with 4002 Top Rail**

**Part 5002- Top Rail Kidron**

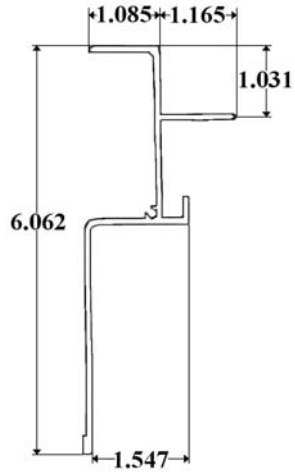

**Part 5004- Kidron New Dry Freight Top Rail**

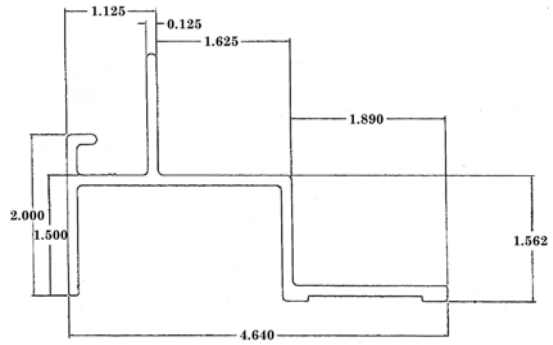

**Part 6002- Top Rail Mickey**

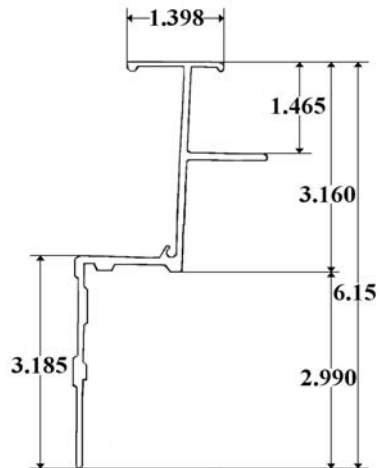

**Part 7002- Top Rail A.M. Haire**

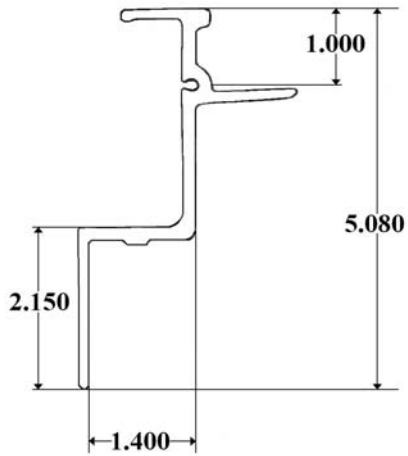

**Part 7701- ABC Body Upper Top Rail**

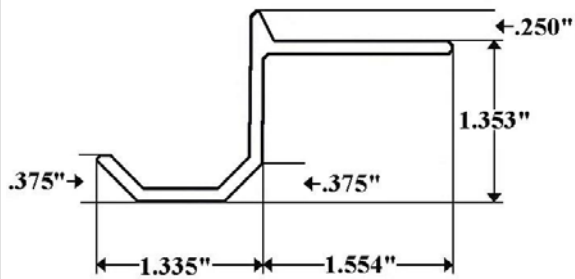

**Use #7702 for Lower Top Rail**

**Part 7702- ABC Body Lower Top Rail**

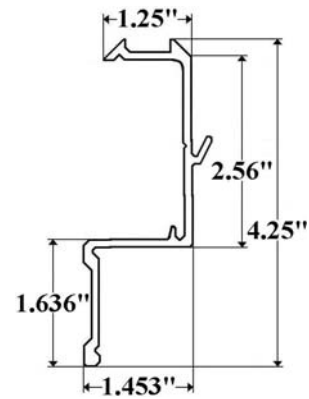

**Use #7701 for Upper Top Rail**

**Part 8002- Top Rail A/C**

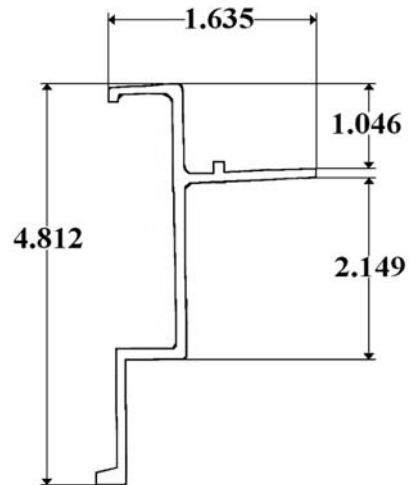

**Part 9001- Top Rail Babb Old Style**

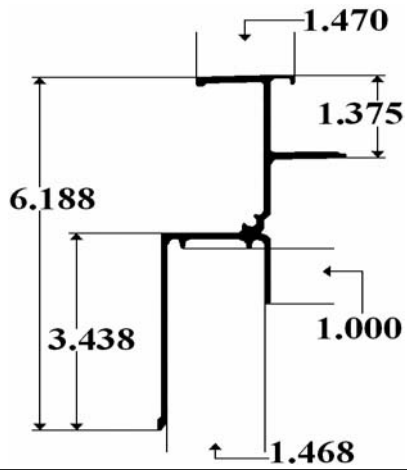

**Part 9002- Top Rail Babb New Style**

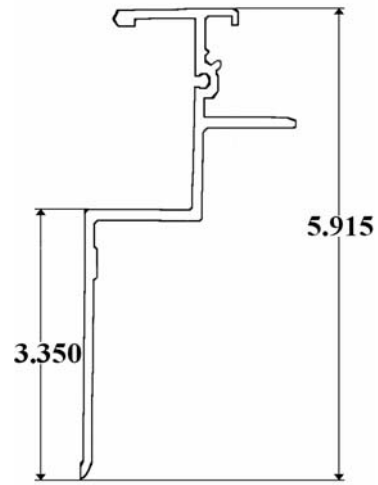

**Part 9902- Marathon/Satellite/Metro Top Rail**

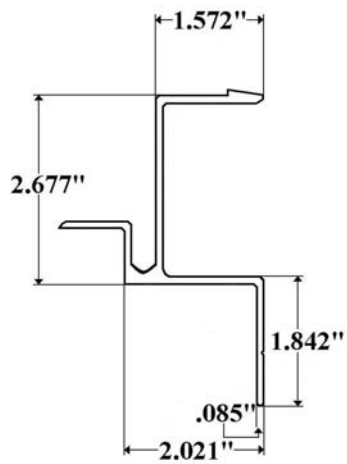

**Part C-531 - Continental Truck Body Top Rail**

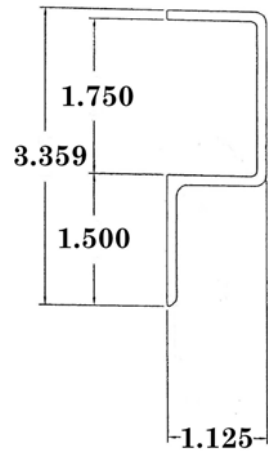

**Part VB804/16 (16')- Replacement Top Rail for Grumman V-Body**

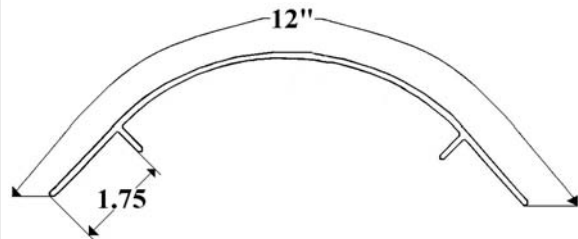

**Must Replace Complete**